

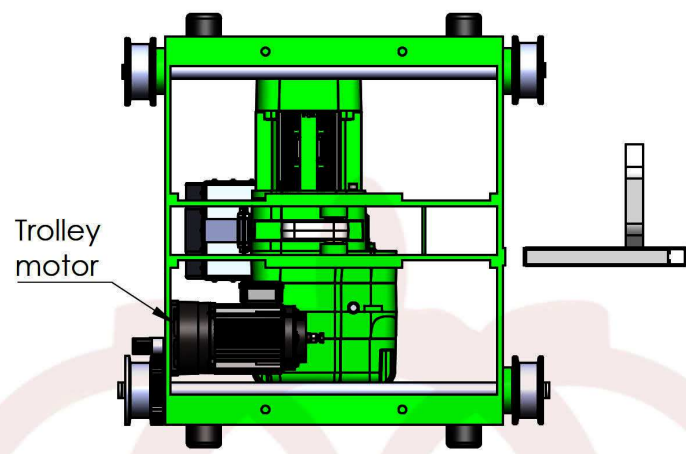

Rotation hook
Dust free wheel (Option)

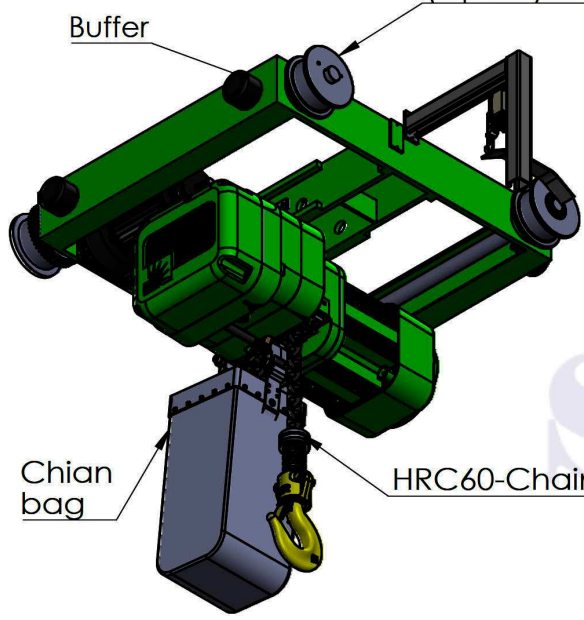

Trolley motor



Buffer
Chian bag
HRC60-Chain

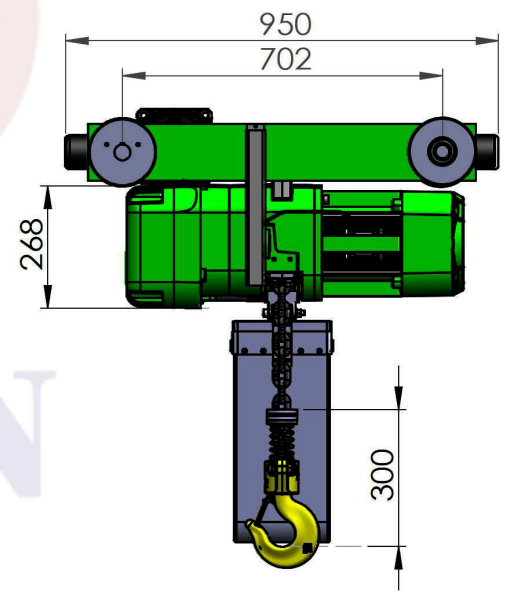
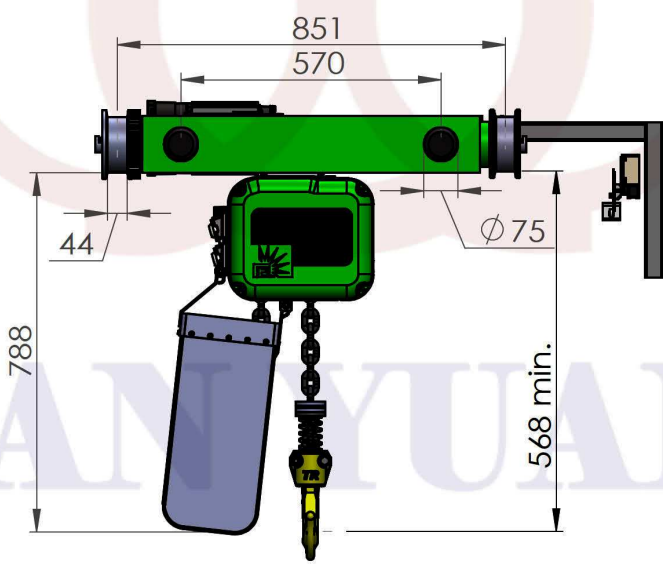

TYPE	ER3-025S-DT	
Cap	2500 Kg	
Test load	3125 Kg	
Lift	6m	
Hoist speed	60Hz	6.8 m/min
	50Hz	5.7 m/min
Hoist motor	5Hp - Inverter	
Trolley speed	60Hz	18 m/min
	50Hz	15 m/min
Trolley motor	0.4Kw 4P	
Chian	11.2x34-1 Fall	
Power	3PH 220V60Hz	
Control	Remote	

設計 DESIGNED BY		日期 DATE		材質 MATERIAL		表面處理 Surface D.W		單位 UNIT	mm	三園立企業股份有限公司 SAN YUAN CHIAN HOIST CORP.	圖名 NAME	ER3-2.5T/Dual rail chain hoist	
核准 APPROVED BY	LEE YU JEN	日期 DATE	2019 JUN25	未標註公差 TOLERANCE	R- C-	比例 SCALE	1:1				圖號 DWG. NO.	ER3-025S-DT	A4L