

型 式		2.8RF-DT	3RF-DT	5RF-DT	7.5RF-DT	10RF-DT	15RF-DT	20RF-DT				
額定荷重 (Ton)		2.8	3	5	7.5	10	15	20				
標準揚程 (M)		6、8、12										
捲上速度 (M/min)	50HZ	5.3	5.3	6	4.2	4.3	4.2	3.5				
	60HZ	6.3	6.3	7.2	5	5.2	5	4.2				
捲上馬達 (Kw)		3.75	3.75	7.5	7.5	11	18.5	18.5				
橫行速度 (M/min)	50HZ	14				15	12					
	60HZ	17				18	15					
橫行馬達 (Kw)		0.37	0.37	0.75	0.75	1.5	1.5	2.2				
鋼索直徑 (mm)		$\Phi 12$	$\Phi 10$	$\Phi 12$	$\Phi 10$	$\Phi 16$	$\Phi 12$	$\Phi 14$	$\Phi 16$	$\Phi 18$	$\Phi 20$	
鋼索掛數		2/1	4/2	2/1	4/2	4/2						
概 略 尺 寸 (mm)	A	6M	455	530	455	530	490	570	625	725	800	820
		8M	455	580	455	580	490	625	675	775	855	880
		12M	530	710	530	710	570	725	805	910	980	1030
	B	6M	625	700	705	780	790	870	930	1020	1060	1090
		8M	625	700	705	830	790	930	980	1070	1115	1140
		12M	700	880	780	960	870	1030	1105	1205	1220	1290
	C	6M	600	750	600	750	600	750	850	900	950	950
		8M	600	850	600	850	600	850	950	1000	1050	1000
		12M	750	1100	750	1100	750	1050	1250	1250	1250	1250
	D	415	415	415	415	480	500	550	680	680	680	
	E	380	380	380	380	440	430	490	575	575		
	F	430	430	430	430	460	500	610	715	715		
	ΦG	120	120	120	120	150	180	200	220	250		
H	630	630	630	630	750	720	830	920	1050			
Φd	60	60	60	60	75	85	100	120	140			
X	44	44	44	44	44	52	52	58	58			
淨重 (Kg)	6M	300	330	330	330	480	520	650	850	1100	1350	
	8M	310	350	310	350	490	560	700	900	1160	1430	
	12M	330	380	330	380	520	620	800	1000	1280	1550	

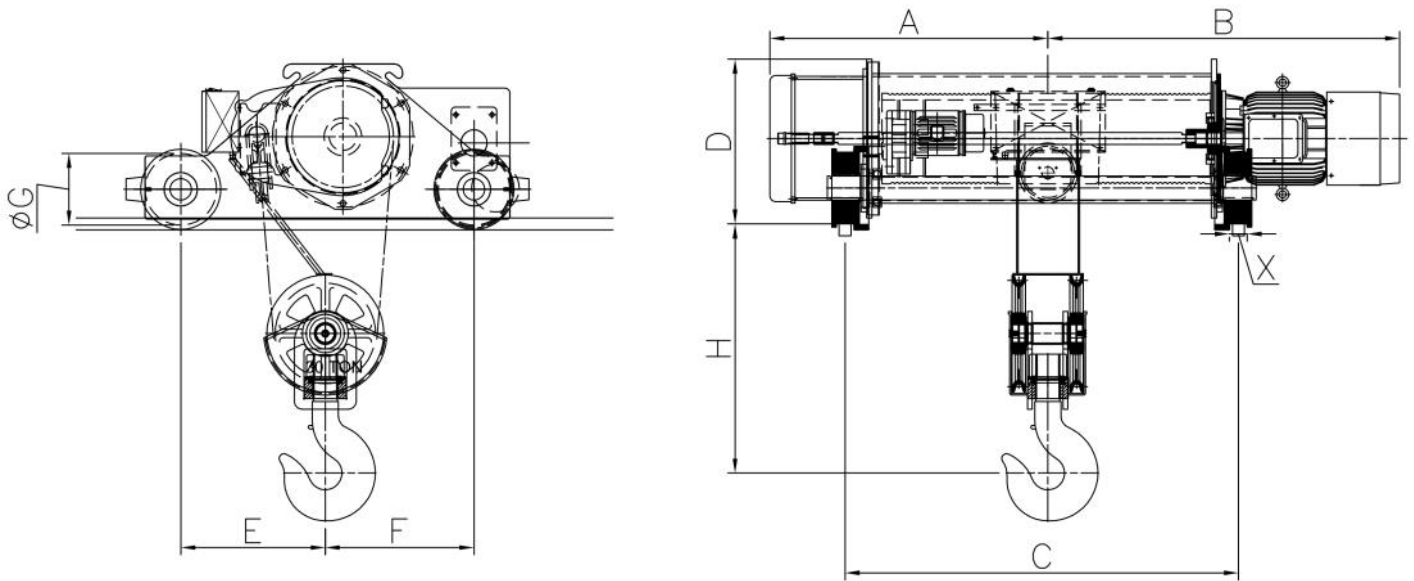

型 式		25RF-DT	30RF-DT		
額定荷重 (Ton)		25	30		
標準揚程 (M)		9、12	9、12	12	
捲上速度 (M/min)	50HZ	3	3.1	2.3	
	60HZ	3.6	3.7	2.8	
捲上馬達 (Kw)		18.5	22.5	22.5	
橫行速度 (M/min)	50HZ	12	12	12	
	60HZ	15	15	15	
橫行馬達 (Kw)		2.2	2.2	1.1 x 2	
鋼索直徑 (mm)		$\Phi 22$	$\Phi 25$	$\Phi 20$	
鋼索掛數		4/2	4/2	6/2	
概 略 尺 寸 (mm)	A	9M	969	1167	*
		12M	1054	1167	1038
	B	9M	1329	1279	*
		12M	1414	1475	1705
	C	9M	1305	1454	*
		12M	1475	1650	1780
	D		690	690	1000
	E		606	606	1130
	F		624	624	670
	ΦG		250	300	300
H		1044	1044	1384	
X		75	75	75	

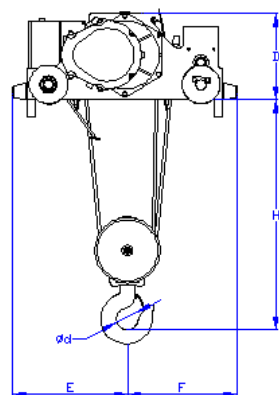
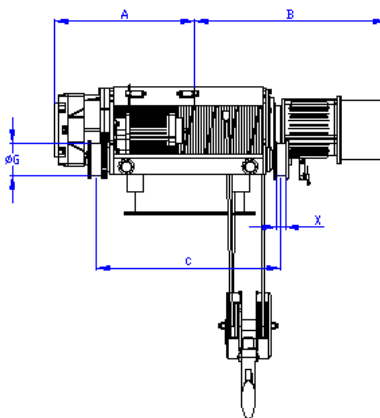

型 式		2.8RS-DT	3RS-DT	5RS1-DT	5RS2-DT	10RS-DT	15RS-DT	20RS-DT	30RS-DT	
額定荷重 (Ton)		2.8	3	5	5	10	15	20	30	
標準揚程 (M)		6、8								
捲上速度 (M/min)	50HZ	3.2	3.2	3	4.6	3	3	2.3	2.1	
	60HZ	3.8	3.8	3.6	5.6	3.6	3.6	2.8	2.5	
捲上馬達 (Kw)		2.2	2.2	3.75	5.5	7.5	11	11	18.5	
橫行速度 (M/min)	50HZ	14			15		12			
	60HZ	17			18		15			
橫行馬達 (Kw)		0.37	0.37	0.75	0.75	1.5	1.5	2.2	2.2	
鋼索直徑 (mm)		Φ12	Φ12	Φ12	Φ12	Φ16	Φ18	Φ20	Φ25	
鋼索掛數		2/1	2/1	4/1	4/1	4/1	4/1	4/1	4/1	
概略尺寸 (mm)	A	6M	455	455	530	530	625	750	780	910
		8M	480	480	580	580	675	825	855	985
	B	6M	630	630	780	780	925	1050	1080	1150
		8M	655	655	830	830	975	1130	1180	1225
	C	6M	600	600	750	750	900	950	1000	1100
		8M	650	650	850	850	1000	1100	1150	1250
	D	415	415	450	450	500	580	580	700	
	E	380	380	430	430	450	625	650	850	
	F	430	430	470	470	550	610	610	650	
	ΦG	120	120	150	150	200	220	250	285	
	H	700	700	700	700	900	1000	1050	1150	
Φd	60	60	75	75	100	120	140	140		
X	44	44	44	44	52	58	58	75		
淨重 (Kg)	6M	280	280	370	370	710	1180	1500	1750	
	8M	300	300	415	415	750	1280	1400	2000	