

TYPE	ER3-050D		Trolley Motor	(Kw)	
Capacity	(Ton)	5	Rating	%ED	
TestLoad		125%	Trolley speed	50 Hz	
Standard lift	(m)	3	(m/min)	60 Hz	
Lift motor	(Kw)	3.75	Beam Width	Standard	
Rating	%ED	60	B, (mm)	Option	
Lift speed (m/min)	50 Hz	2.5	Push Button Cord, L	(m)	2.8
	60 Hz	3	NetWeight	(kg)	184
Load Chain Diameter (mm) x Falls	11.2 x 2		Additional Weight	(kg/m)	5.6

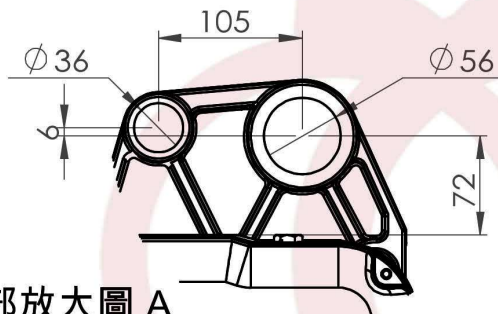

細部放大圖 A  
比例 1 : 5

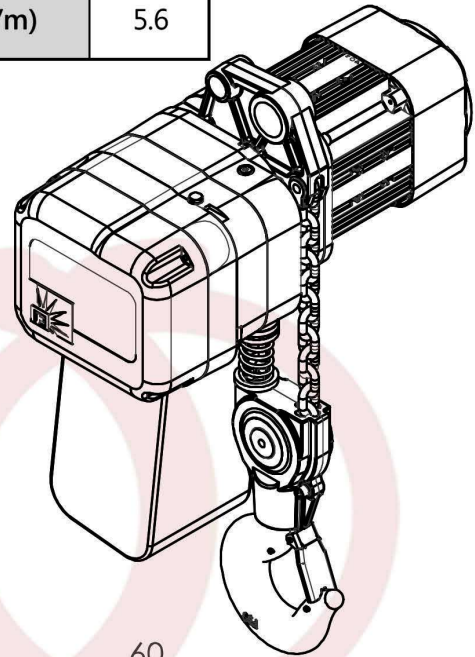
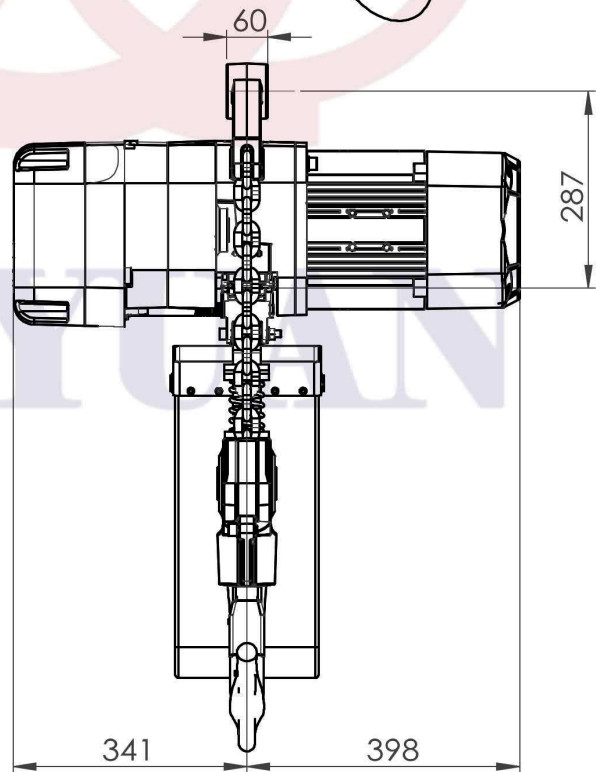
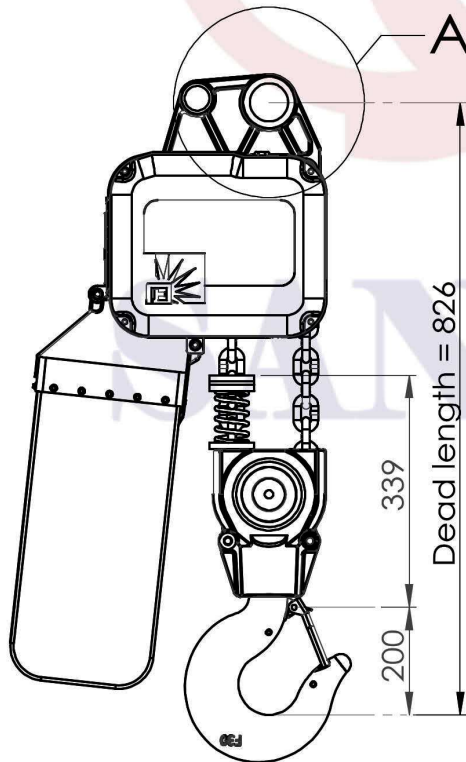

Инв. № подл.	Подп. и дата	Взам. инв. №	Инв. № дубл.	Подп. и дата
Изм.	Лист	№ докум.	Подп.	Дата

李宇仁 18Mar01

三園立企業股份有限公司

Лист